

# FIREPIT BURNER/PAN KIT

BK-36-ROUND

(FITS THE "TIBURON" FP-56)

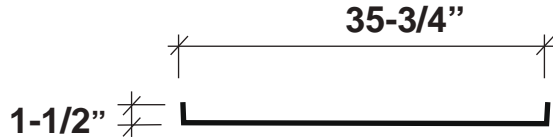

**SIDE VIEW**

**35-3/4" DIA.**

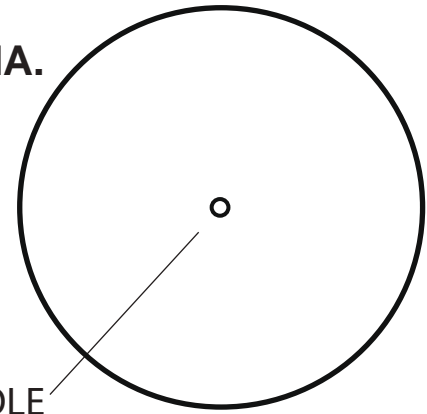

**TOP VIEW**

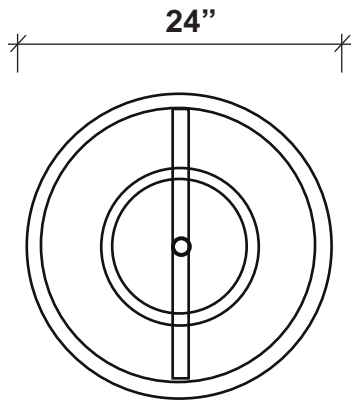

**BURNER-18R**

**PAN-34R**

- 1 STAINLESS PAN
- 1 SS BURNER
- 2 FLEX GAS LINES
- 4 SS CLIPS

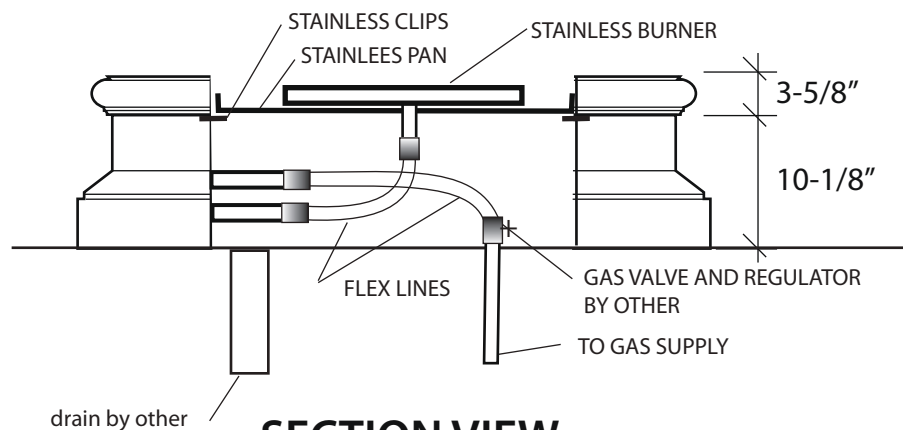

**SECTION VIEW**

**OPTIONAL FIRE GLASS REQUIREMENTS**

PAN-34R (FP-56) 100 LBS.

**ONLY USE LAVA ROCK OR FIRE GLASS**

Product	Dimensions
PAN-36R	35-3/4" DIA. X 1-1/2" DP ROUND SS PAN
BURNER-18R	18" ROUND SS BURNER
BK-36-ROUND	KIT 35-3/4" ROUND SS PAN, 18" ROUND SS BURNER, (2) 36" FLEX LINES