

# FIREPIT BURNER/PAN KIT

BK-28-SQ  
(FITS THE "SOLANA" FP-48)

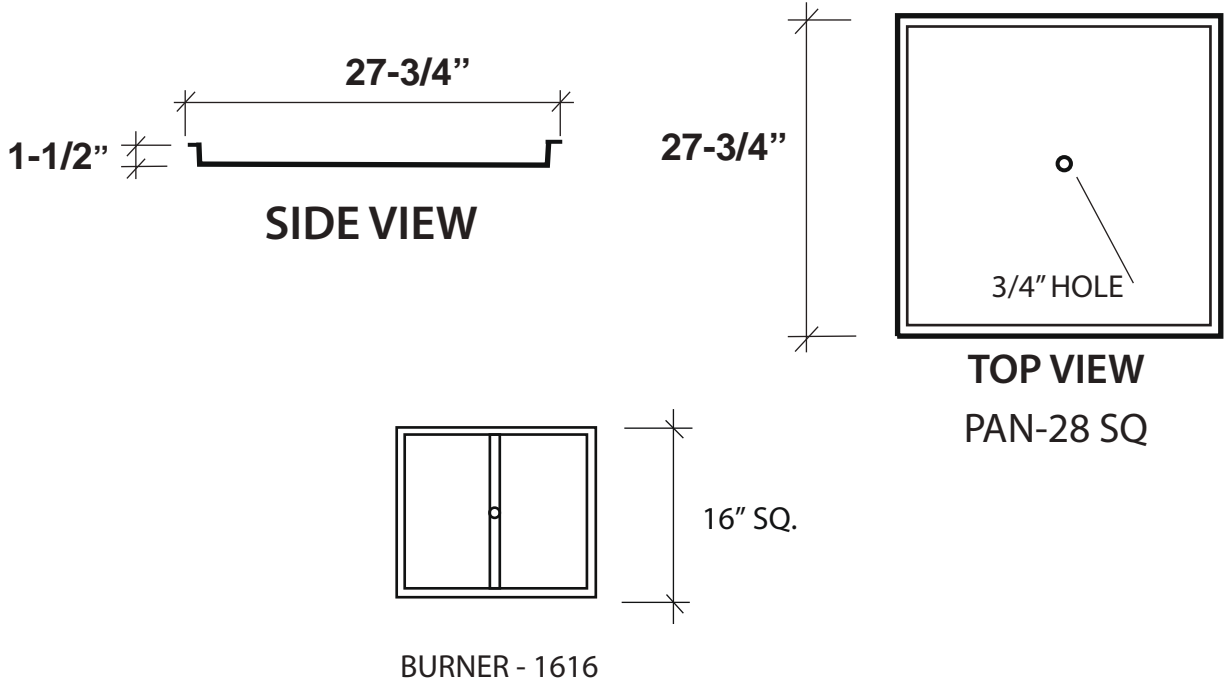

- 1 STAINLESS PAN
- 1 SS BURNER
- 2 FLEX GAS LINES
- 4 SS CLIPS

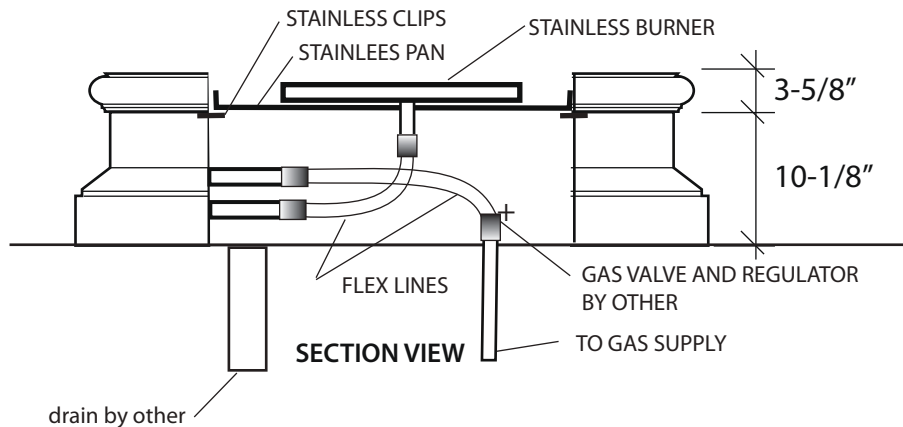

**OPTIONAL FIRE GLASS REQUIREMENTS**

PAN-28 SQ (FP-48) 80 LBS.

**ONLY USE LAVA ROCK OR FIRE GLASS**

Product	Dimensions
PAN-28SQ	27-3/4" X 27-3/4" X 1-1/2" DP SQUARE SS PAN
BURNER-1616	16" SQUARE SS BURNER
BK-28-SQ	28" SQ. SS PAN, 16" SQ. SS BURNER, (2) 36" FLEX LINES