

# FIREPIT BURNER/PAN KIT

BK-1240-RECT CUBIX  
(FITS THE "CUBIX 60")

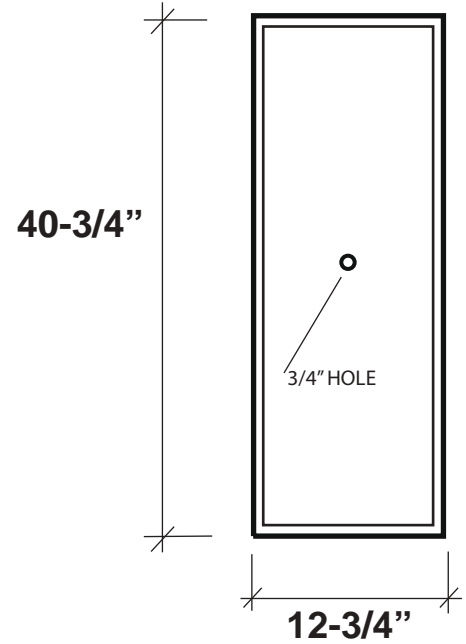

- 1 STAINLESS PAN
- 1 SS BURNER
- 2 FLEX GAS LINES

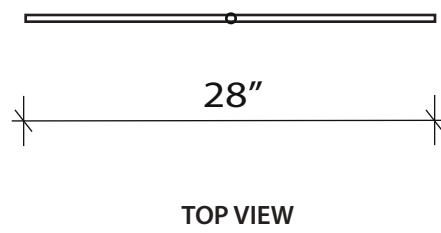
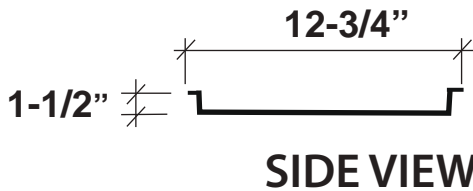
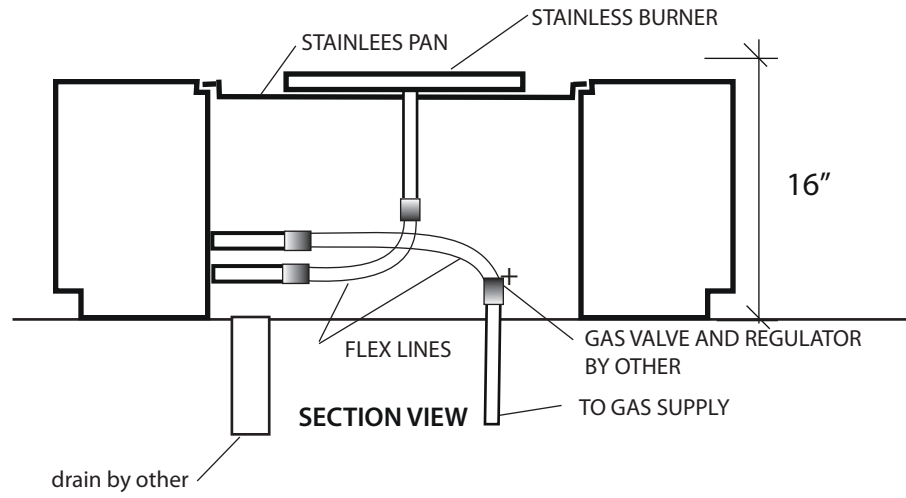

**OPTIONAL FIRE GLASS REQUIREMENTS**

PAN-1240 RECT (CUBIX 60) 50 LBS.

**ONLY USE LAVA ROCK OR FIRE GLASS**

Product	Dimensions
PAN-1240 RECT	12-3/4" X 40-3/4" X 1-1/2" DP RECT SS PAN
BURNER-28	28" STRAIGHT SS BURNER
BK-1240-RECT CUBIX	12-3/4" X 40-3/4" RECT SS PAN, 16" SQ. SS BURNER, (2) 3/6" FLEX LINES